

# Self- operated Regulators Series 42



## Differential Pressure Regulator

**Type 42-25** • The valve opens when pressure differential rises

### with 3 valve isolating manifold

#### General Description

The purpose of this regulator is to restrict the circulating head applied to circuits connected to large heating and other systems where, because of the size of the distribution network and large fluctuations of demand, the pressure differential may vary considerably at different times of the day and night.

The Regulator is sensitive only to the pressure drop across, or circulating head applied to, the controlled circuit and various ranges are available to suit the designed level. It is nearly unaffected by the static head or pressurization applied on larger systems.

The installation is typically at the end of a main-circuit.

The preferred installation is with the actuator vertically below the valve body.

#### Location of installation

Differential Pressure Regulators Type 42-25 have to be mounted in a by-pass pipe between flow and return and are usually assembled in our works to minimize the number of site connections. The connection arrangements are shown in Fig. 1.

The flow pipe pressure is connected to the topside of the actuator marked (+) via the 3 valve isolating manifold mounted on the actuator. The return pipe pressure is similarly transmitted to the under side of the actuator.

3/8" copper or stainless steel tube is often used to make this connection

#### Three Valve Assembly

Because the control valve must be sensitive to very small changes of pressure differential, typically a few inches w.c. it is very easily damaged if the system static pressure is allowed to act on one side of the diaphragm only. This can happen during the process of filling the system or if part of the circuit is shut off in order to clean a strainer.

The purpose of the 3 valve manifold (see Fig. 2) mounted on the valve during manufacture is first of all, to enable the diaphragm

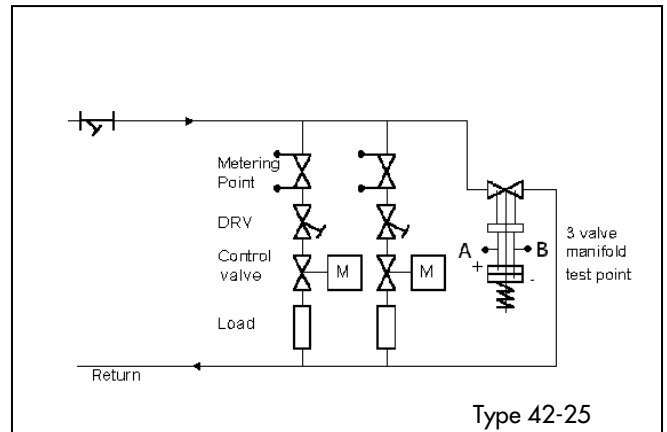

Fig. 1 • Location of installation

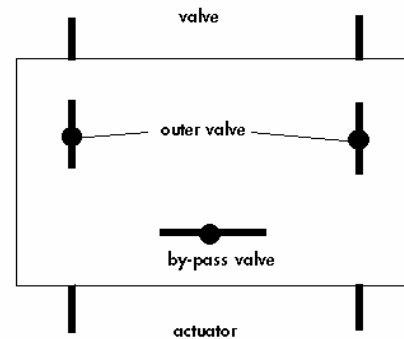

Fig. 2 • Three valve isolating manifold

chambers to be isolated from the system flow and return pressures and secondly, to enable the pressures in the upper and lower chambers to be equalized.

In any situation which could involve the de-pressurization of either the flow or return pipes

#### First

- close the two outer valves
- open the centre (by-pass) valve

After the system has turned on again

- open the two outer valves
- close the center (by-pass) valve

If this simple routine is followed correctly there is no risk of damaging the diaphragm.

It follows that at time of installation the outer valves must be shut and the by-pass open.

#### Commissioning procedure

It is assumed that the systems will have been filled, pressurized and the main circulating pumps will be running.

Mechseal test points have been fitted to the actuator. A good quality differential pressure gauge of suitable range should be connected so as to display the head across the circuit.

Open the outer valves fully and close the by-pass.

The valve is now operational and the spring adjuster nut underneath the bottom pressure plate may be adjusted until the desired pressure differential is achieved.

#### Introduction

The circuits shown in Fig. 1 are a typical installation of a type 42-25 differential pressure regulator. The intention is that the motorized valve controlling the load will have good authority.

#### Commissioning Procedure

1. Ensure that the impulse connections to the diaphragm actuator are connected to the flow and return pipes. Isolating valves, three-valve isolating manifold and test points etc. may be included in the impulse pipes. It is desirable to be able to measure the pressures where test points A, B are shown.

It is necessary to control the pressure drop across the motorized valves, loads, and double regulating valves (DRV). The drawing Fig. 3 shows this. It is not possible to achieve 100% valve authority but acceptably high values can be obtained (30-50%).

The differential pressure regulator has to be adjusted so that the sub-circuit requiring the highest differential is catered for. For example, suppose that the minimum pressure drop across MV1 and Load 1 at design flow is 4 psi, and the minimum pressure

drop across MV2 and Load 2 at design flow is 6 psi. The differential pressure controller must be adjusted to control a differential of 5.5 psi + a suitable allowance for the pressure drop through pipe-work and the associated DRV. This might typically come to 7 psi.

With each motorized valve fully closed, the DRVs should be adjusted until the design pressure differential is achieved.

The differential pressure regulator is now commissioned.

3. To check that the differential pressure regulator is working correctly, measure the pressure differential across the sub-circuit (A-B) and note how it changes if the motorized valve is moved through its stroke. There will be some rise in differential measured because the differential pressure regulator provides proportional control, but until the motorized valve is nearly closed, there should not be a significant rise in controlled differential.

#### Point to consider during commissioning

4. The circuit can only operate correctly as described above if there is sufficient differential on the supply side at all load conditions to overcome the sub-circuit resistance. The difference between pressures at A-B must be equal to the design pressure drops for the sub-circuit. This should be checked at full load to check that there is sufficient head available.

#### Fault Finding

$\Delta$ .P. Valves should be installed as Data Sheet instructions.

##### 1. Lack of Flow

- Insufficient Mains differential available.  
If spring is fully decompressed and still low flow, then check motorized valves fully open, strainers are not blocked (or any pipe work blocked).
- If sufficient mains  $\Delta$ .P. is available then spring range not high enough.  
Check impulse lines are connected properly.

##### 2. Too Much Flow

- Sub-circuit resistance small compared to spring range.

##### 3. System oscillation

- Reduce position outer valve (-) in small steps until oscillation stops. Don't shut off the outer valve.

**Note:** Valve opens on increased pressure differential. (Valve is in a normally open position).