

Pneumatic Control Valve Type 3525-1

Globe Valve Type 3525 ANSI Class 900



Fig. 1 - Pneumatic Globe Valve Type 3525 - Class 900

Mounting and Operating Instructions

EB 8823

Revision February 2009

Safety instructions



- ▶ *Assembly, start-up and operation of the device may only be performed by trained and experienced personnel familiar with this product.*
- ▶ *According to these Mounting and Operating Instructions trained personnel refers to persons who are able to judge the work they are assigned and to recognize possible dangers due to their specialized training, knowledge, and experience as well as their knowledge of the relevant standards.*
- ▶ *Any hazards which could be caused by the process medium, the signal pressure and moving parts of the control valve are to be prevented by means of appropriate measures.*
- ▶ *In addition, you are required to make sure that the control valve is only used for applications where operating pressure and temperatures do not exceed the operating values that are based on the valve sizing data submitted in the order.*
- ▶ *Proper shipping and appropriate storage are assumed.*

Contents

1	Design and principle of operation	4
1.1	Fail-safe position	4
1.1.1	Actuator stem extends	4
1.1.2	Actuator stem retracts	4
	Technical data	6
2	Assembly of valve and actuator, C_v adjustment	7
3	Installation	8
3.1	Position of installation	8
3.2	Signal pressure line	8
4	Troubleshooting	8
4.1	Replacing the seat, plug, and packing	9
4.1.1	Replacing the seat for stem extends if supply air is unavailable	9
4.1.2	Replacing the seat for stem retracts	9
4.1.3	Replacing the plug	10
4.1.4	Replacing the packing	10
4.2	Reversing the fail-safe action to actuator stem retracts	10
4.3	Replacing the diaphragm	11
4.4	Replacing the actuator seal, wiper and bearing	11
5	Nameplate description	12
6	Customer inquiries	12
7	Dimensions in mm and weights	13
8	Spare parts	14

1 Design and principle of operation

The Type 3525 Pneumatic Control Valve consists of a single-seated Type 3525 Globe Valve and a pneumatic actuator.

The process medium flows through the valve in the direction indicated by the arrow on the valve body. The valve normally operates in the flow-to-close (FTC) direction (i.e. the medium should flow across the plug (23) from top to bottom). See Fig. 1.

The plug position is changed by the signal pressure acting on the actuator diaphragm.

The plug stem (22) and actuator stem are connected by a stem connector (34). The plug stem is sealed by a spring-loaded V-ring packing assembly (12).

1.1 Fail-safe position

The control valve has two possible fail-safe positions depending on the arrangement of the actuator plate and springs:

1.1.1 Actuator stem extends

When the signal pressure is reduced the compression springs (41) force the actuator stem downward, thereby closing the valve.

When the signal pressure increases the valve opens by acting against the compression spring force.

1.1.2 Actuator stem retracts

When the signal pressure is reduced the compression springs (41) force the actuator stem upward, thereby opening the valve.

When the signal pressure increases the valve closes by acting against the compression spring force.

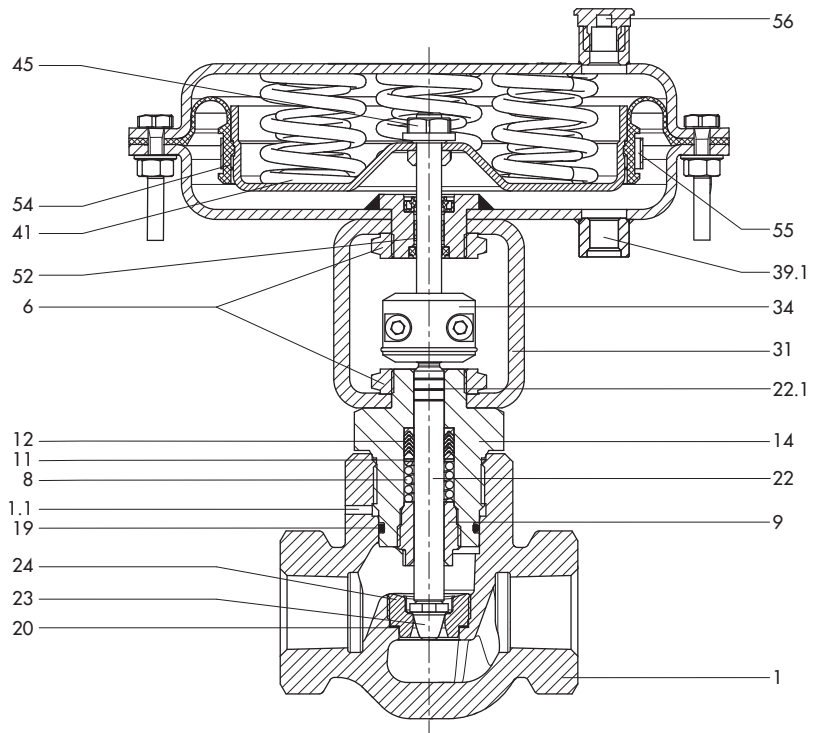

Legend

1 Body	19 Ring gasket *	39.1 Air connection
1.1 Safety bleed	20 Seat gasket *	41 Spring (standard)
6 Nut	22 Stem (standard) *	45 Diaphragm lock nut *
8 Spring	22.1 Cv travel marks	52 Plain bearing *
9 Guided bushing *	23 Plug (standard) *	54 Diaphragm assy. *
11 Washer	24 Seat (standard) *	55 Diaphragm clamp
12 V-ring packing *	31 Yoke	56 Vent plug
14 Flange	34 Stem connector	* Parts subject to wear

Fig. 2 · Type 3525-1 Pneumatic Control Valve

Design and principle of operation

1.2 Technical data

Valve	Size	NPS 1
Flow rate		C _v 2 · C _v 4 · C _v 6
ASTM material		A 352 LCC
End connections		Female threads
Type of connection		1"-11.5 NPT
Pressure rating		Class 900
Seat-plug sealing		Metal sealing
Characteristic		On-off
Temperature range		-50 to 300 °F · -46 to 149 °C
Leakage class		IV

Materials	
Valve body	A 352 LCC
Valve bonnet	A 352 LCC
Seat and plug	Stellite 6B or tungsten carbide
Guide bushing	A 479 316 L
Packing	PTFE · NACE compatible · Spring: Hastelloy C4
O-ring	HNBR

Actuator	
Diaphragm area	240 cm ²
Bench range	Stem extends: 20 to 50 psi Stem retracts: 3 to 15 psi
Required supply pressure	18 psi stem retracts · 53 psi stem extends
Max. supply pressure	60 psi
Fail-safe action	Fail-close or fail-open
Materials	
Diaphragm cases	Sheet steel
Rolling diaphragm	NBR with fabric insert
Actuator stem	A 479 316 L

2 Assembly of valve and actuator, Cv adjustment

The valve and actuator are supplied by the manufacturer fully assembled in either the stem extends (fail-close) or stem retracts (fail-open) configuration.

All valves supplied by the manufacturer are set to Cv 6. To view the current Cv setting of the valve retract the stem fully. For a valve with actuator stem retracts, this is accomplished by removing the actuator signal. For a valve with actuator stem extends, apply a 50 psi signal. The number of lines visible on the plug stem corresponds to the Cv:

Cv 2	-	1 line
Cv 4	-	2 lines
Cv 6	-	3 lines

Caution!

Loosening the stem connector before removing the forces acting on the stem could cause bodily harm to anyone in the area as well as damage the valve itself. Only trained specialists should proceed with the changing of the Cv value.

To change the Cv setting proceed as follows:

1. Move the actuator stem to its topmost position.
Stem retracts – remove any signal to the actuator.
Stem extends – apply a 50 psi signal to the actuator.
2. Remove the stem connector (34) with a 5 mm hex key.
3. Remove the two halves of the stem connector from the stem.
4. Raise or lower the plug stem (22) so that the line corresponding to the necessary Cv value is flush with the top of the bonnet (14).
5. Replace the two halves of the stem connector and tighten the stem connector screws evenly.

3 Installation

3.1 Position of installation



Important!

The valve should be installed vertically with the actuator pointing upward and must be installed free of stress.

If necessary, support the pipeline near to the valve connections.

Do not mount supports on the valve or actuator.

Thoroughly flush the pipelines prior to installation of the valve.

3.2 Signal pressure line

Stem retracts (3525-0003):

Connect the signal pressure line to the upper pneumatic connection port (remove vent plug 56) in Fig. 2.

Stem extends (3525-0009):

Connect the signal pressure line to the lower pneumatic connection port (39.1) in Fig. 2.

4 Troubleshooting

Leakage at the bonnet could be caused by a worn or damaged packing (12). A damaged O-ring (19) will bleed the process media at the safety bleed (1.1).

If the valve does not close properly dirt or other impurities could be caught between the seat and plug or the sealing edges of the seat and/or plug may be damaged.

The valve should be disassembled, thoroughly cleaned, and damaged parts should be replaced as necessary.



Caution!

Before servicing or disassembling the control valve, you must relieve the pressure and drain the line from the section of the plant containing the valve.

You should remove the control valve from the pipeline. Allow the line and valve to cool adequately before servicing.

4.1 Replacing the seat, plug, and packing

1. For stem extends apply 50 psi to the actuator.
2. Remove the stem connector (34) from the plug and actuator stem.
3. Remove the lower locknut (6) from the bonnet (31) yoke assembly.
4. Separate the yoke/actuator assembly from the bonnet/body assembly.
5. Using a suitable wrench, remove the bonnet (14) from the valve body.
6. Remove the seat (24) with a $\frac{3}{4}$ " hex key.
7. Remove the gasket (20).
8. Thoroughly clean the threads and gasket sealing surface.
9. Replace the gasket with a new part. Apply anti-galling grease (SAMSON part number 8150-0119) to the threads of the new seat and reinstall.

4.1.1 Replacing the seat for stem extends if supply air is unavailable

1. For stem extends remove short actuator bolts using two 13 mm or $\frac{1}{2}$ " wrenches.
2. Slowly loosen the long tensioning bolts in cross-wise pattern so the actuator top plate is raised in a level manner until there is no tension in the springs. Ensure threads are lubricated.
3. Remove the stem connector (34) from the plug and actuator stem.

4. Remove the lower locknut (6) from the bonnet (14) yoke (31) assembly.
5. Separate the yoke/actuator assembly from the bonnet/body assembly.
6. Using a suitable wrench, remove the bonnet (14) from the valve body.
7. Remove the seat (24) with a $\frac{3}{4}$ " hex key.
8. Remove the gasket (20).
9. Thoroughly clean the threads and gasket sealing surface.
10. Replace the gasket with a new part. Apply anti-galling grease (SAMSON part number 8150-0119) to the threads of the new seat and reinstall.

4.1.2 Replacing the seat for stem retracts

1. Remove signal to the actuator.
2. Remove the stem connector (34) from the plug and actuator stem.
3. Remove the lower locknut (6) from the bonnet (14) yoke (31) assembly.
4. Separate the yoke/actuator assembly from the bonnet/body assembly.
5. Using a suitable wrench, remove the bonnet (14) from the valve body.
6. Remove the seat (24) with a $\frac{3}{4}$ " hex key.
7. Remove the gasket (20). Thoroughly clean the threads and gasket sealing surface.
8. Replace the gasket with a new part. Apply anti-galling grease (SAMSON part number 8150-0119) to the threads of the new seat and reinstall.

4.1.3 Replacing the plug

1. Follow the appropriate disassembly procedure outlined in above section.
2. Remove the plug (23) using a 9/16" wrench. Heat may be required to loosen the plug from the stem.
3. Attach a new plug to the plug stem (22). Use a suitable thread locking compound (SAMSON part number 8121-3022) to secure the plug.

4.1.4 Replacing the packing

1. Follow the appropriate disassembly procedure outlined in above section.
2. Remove the plug as outlined above.
3. Remove the packing bushing (9) using an 11/16" wrench.
4. Slide the stem (22) downward to remove the packing. If this does not work, remove the stem and the packing rings (12) with an appropriate tool, taking care not to damage the walls of the packing chamber.
5. Clean the packing chamber thoroughly.
6. Replace the damaged packing parts. Apply lubricant (SAMSON part number 8150-0111) generously to the packing rings, plug stem, and packing nut.
7. Replace the plug as outlined above.
8. Reassemble the bonnet, yoke and actuator. Set the Cv as outlined in section 2.

4.2 Reversing the fail-safe action to actuator stem retracts

1. Remove short actuator bolts using two 1/2" or 13 mm wrenches.
2. Slowly loosen the long tensioning bolts in cross-wise pattern so the actuator top plate is raised in a level manner until there is no tension in the springs.
3. Remove the stem connector (34) from the plug and actuator stem (7).
4. Finish removing the long tensioning bolts. Lift off the actuator top plate.
5. Remove all springs from the actuator and lift the diaphragm plate, diaphragm and stem assembly from the lower actuator housing.
6. Using two 11/16" or 17 mm wrenches loosen and remove the top nut (45) (PTFE lined) being careful not to disturb the lower nut (5) position.
7. Flip the actuator plate 180 degrees and reinstall the stem and lock nut.
8. Place three of the large actuator springs evenly on the lower actuator housing and line them up to match the dimples on the diaphragm plate.
9. Lower the diaphragm plate onto the lower housing and ensure the dimples are on the inside of the springs.
10. Reinstall the actuator top plate and all bolts, washers and nuts.
11. Set the Cv as in Item 2 under Assembly of valve and actuator, Cv Adjustment.

4.3 Replacing the diaphragm

1. Use the appropriate disassembly method for the fail action of the actuator outlined in section 4.
2. Remove the diaphragm plate, diaphragm and actuator stem from the actuator housing.
3. Remove the hose clamp and pull the diaphragm from the diaphragm plate.
4. Slide the new diaphragm over the diaphragm plate the raised face of the diaphragm must sit correctly in the groove of the diaphragm plate.
5. Install hose clamp and tighten to a torque of 53 in lbs or 6 Nm.

4.4 Replacing the actuator seal, wiper and bearing

1. Before reinstalling the diaphragm plate. Using a blunt screw driver carefully pry out the seal ring and wiper ring.
2. Using a suitable drift gently tap the old bearing from the housing.
3. Install the new bearing so that it is flush with the housing under the seal area of the actuator.
4. Install the new seal.
5. Install the new wiper ring.
6. Reassemble the actuator.

Nameplate description

5 Nameplate description

1. Order/serial number
2. Position number
3. Model number
 - a. 0003 – Stem retracts
 - b. 0009 – Stem extends
4. Actuator spring range
5. Actuator operating range

6 Customer inquiries

Should you have any questions, please submit the following details:

1. Type and model number of valve from order or nameplate.
2. Pressure and temperature of the process.
3. Flow rate in m³/h.
4. Installation drawings (if available).

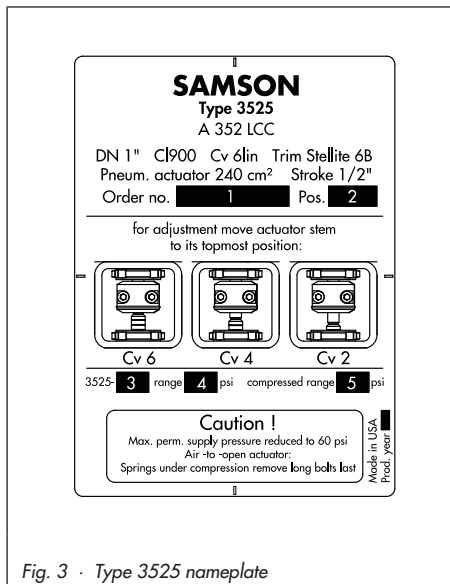
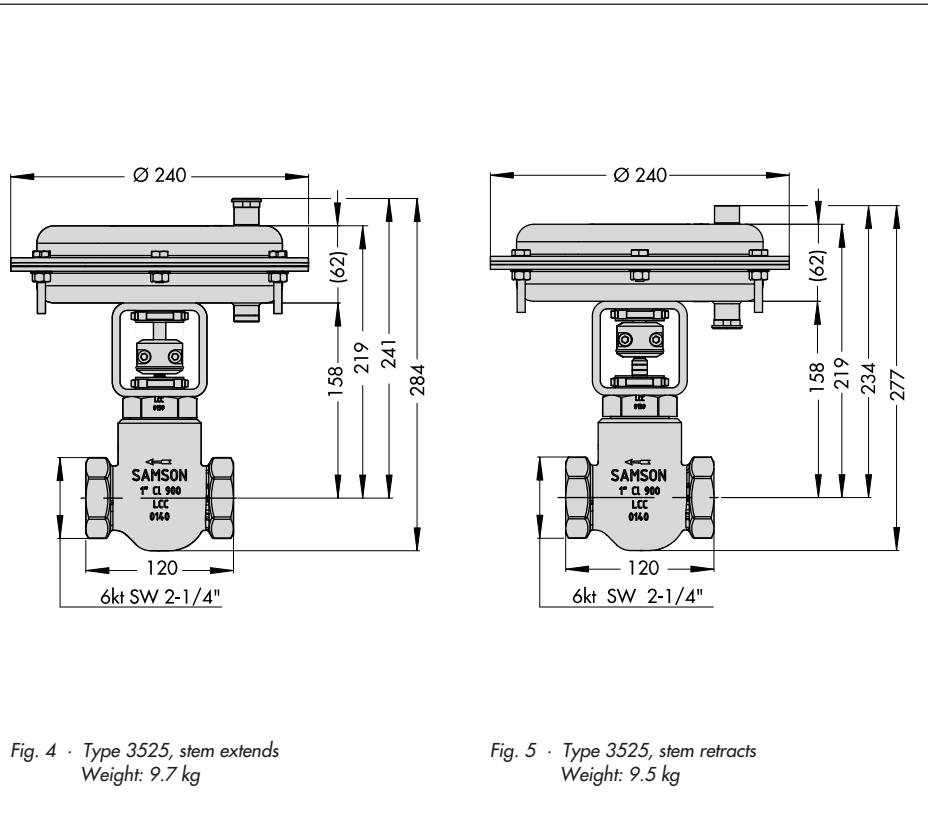

Fig. 3 · Type 3525 nameplate

7 Dimensions in mm and weights



8 Spare parts

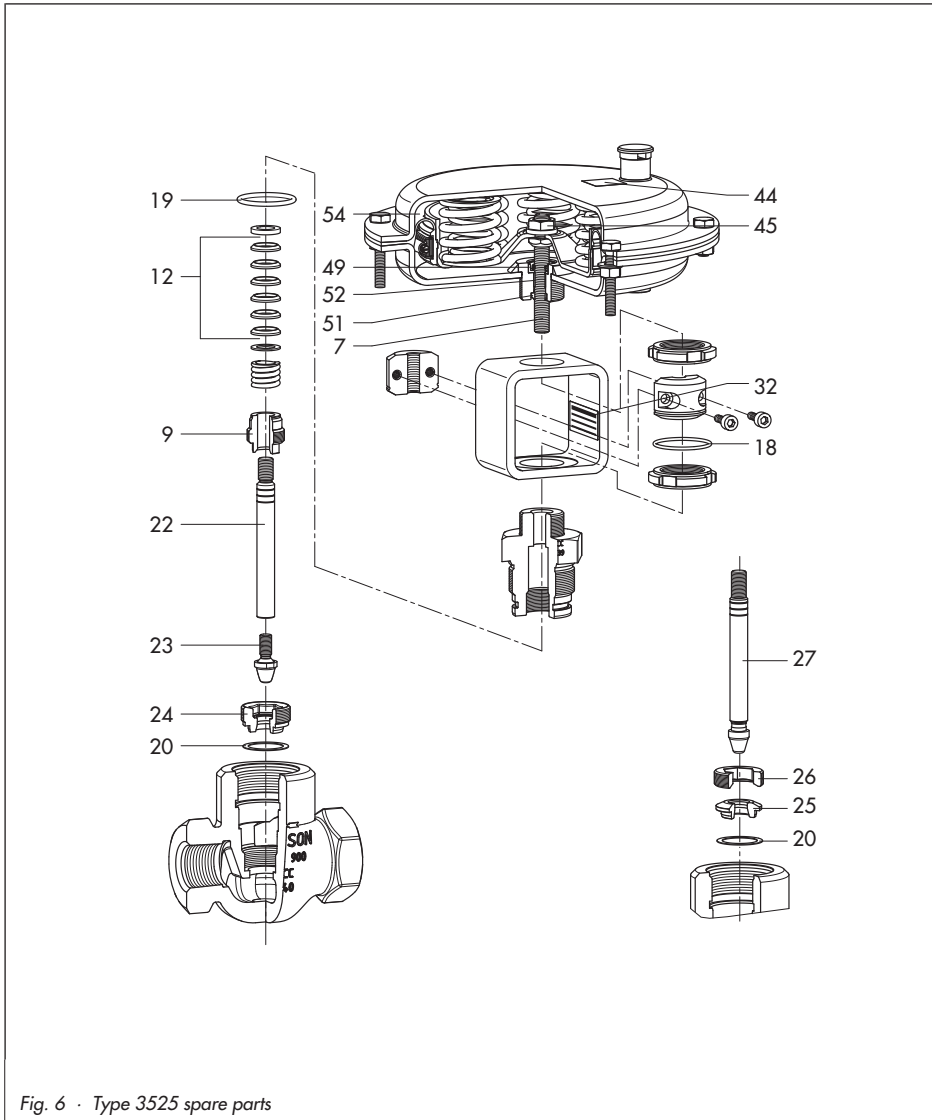

Fig. 6 · Type 3525 spare parts

Spare Parts List

Drw. no.	Description	Part no.
Type 3525 Valve		
9	Guided bushing	0319-8001
12	PTFE V-ring packing	0430-0618
19	O-ring gasket	8421-1006
20	Seat gasket	8414-2510
22	Stem (Stellite 6B)	0299-8001
23	Plug (Stellite 6B)	0229-8001
24	Seat (standard)	0119-8051
25	Tungsten carbide seat	0119-8052
26	Threaded seat ring	0119-8053
27	Tungsten carbide plug with stem	1099-8005
Actuator		
7	Actuator stem	0299-8002
45	Lock nut M10	8353-0533
49	Gasket	8406-0025
51	Wiper ring	8429-0129
52	Plain bearing	8485-0005
54	Diaphragm	0520-0498



SAMSON Controls Inc.
1-105 Riviera Drive
Markham - Ontario - L3R 5J7
Tel. (905) 474-0354
Fax (905) 474-0998

SAMSON Controls Inc.
4111 Cedar Boulevard
Baytown - Texas - 77520
Tel. (281) 383-3677
Fax (281) 383-3690

EB 8823

2009-03